

# CARD GUIDE

TOOL CODE A0

Pre-pierce ends can be rectangular or rectangular with radiused corners

RECOMMENDED PRE-PIERCE TABLE  
Based on .076(1.9) card guide width

Material Thickness	"B"	"F"
.059(1.5)	.080(2.0)	.284(7.2)
	.090(2.3)	.304(7.7)
	.100(2.5)	.324(8.2)
	.125(3.2)	.374(9.5)
.048(1.2)	.080(2.0)	.274(7.0)
	.090(2.3)	.294(7.5)
	.100(2.5)	.314(8.0)
	.125(3.2)	.364(9.2)

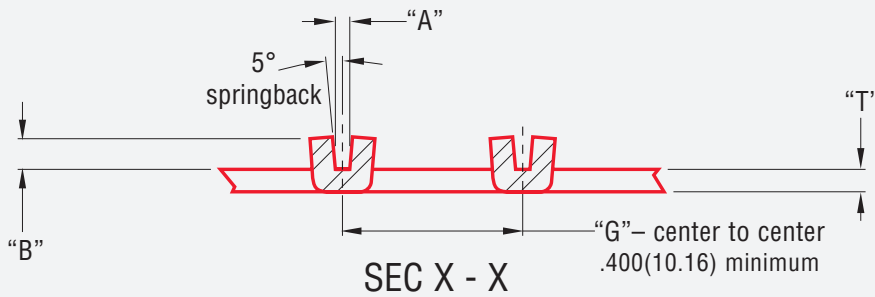
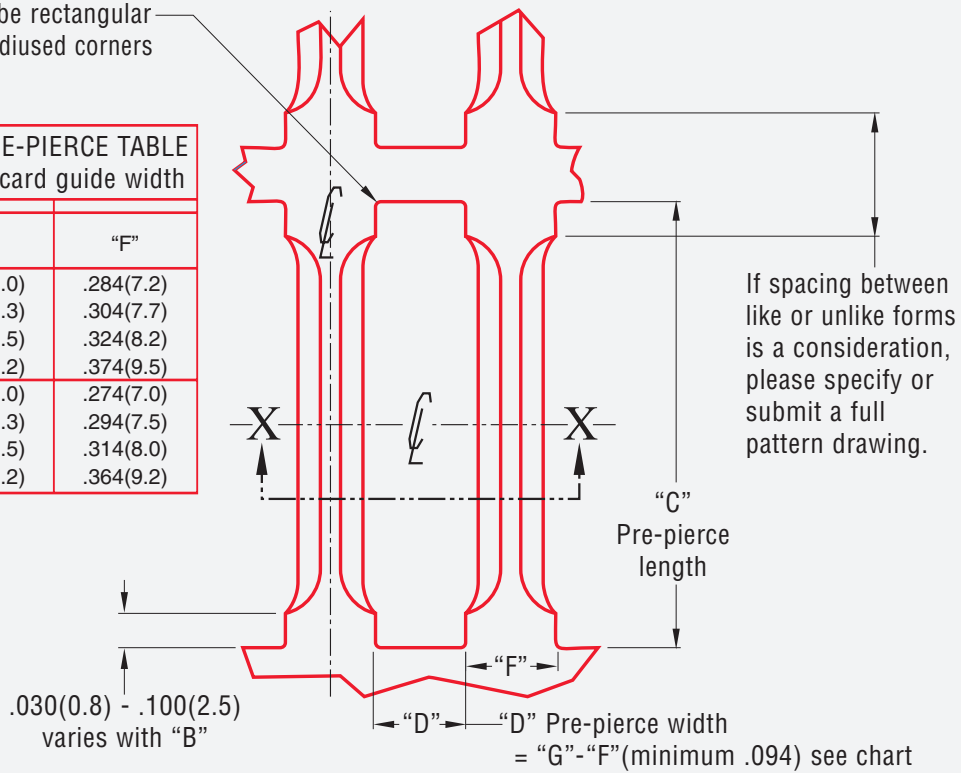

## TOOL INFORMATION

To manufacture a tool to your specifications please provide the following dimensions.

A \_\_\_\_\_ G \_\_\_\_\_

B \_\_\_\_\_

C \_\_\_\_\_

D \_\_\_\_\_

F \_\_\_\_\_

\* If not specified, determined by MATE

## GENERAL INFORMATION

Material Type \_\_\_\_\_

Material Thickness "T" \_\_\_\_\_

Machine Type \_\_\_\_\_

Tooling Style \_\_\_\_\_

Tooling Station \_\_\_\_\_

Dimensions filled in by \_\_\_\_\_

Approved By \_\_\_\_\_

Dimensions in inches (millimeters)

